

In case of discrepancies between the French and the English text,
the French text shall prevail

Manual of electronic transmission for statistical reports of investment funds

Contents

1	Introduction	3
2	Transmission.....	4
	2.1 Attribution of the file name for regulated investment funds	4
	2.2 Attribution of the file name for Luxembourg’s non-regulated investment funds..	5
	2.3 File names currently in use for regulated investment funds.....	6
	2.4 File names currently in use for Luxembourg’s non-regulated investment funds.	6
	2.5 Means of transmission	7
3	XML schemes for statistical reports.....	8
4	Identification of the reporter and the declarant.....	8

1 Introduction

This manual details the technical characteristics that must be observed for the electronic transmission of statistical reports by regulated investment funds (UCI, SIF, SICAR) and non-regulated (RAIF and others).

The instructions relating to the statistical reporting are described in the documents Instructions and Report relating to the statistical reports of investment funds.

The objective of this manual is to describe the general principles of the reporting in XML format applicable for the statistical reports of investment funds. The XML scheme and a technical documentation are available for downloading on the BCL's website. It is important to know that the design of the XML reporting is based on a tree-structured menu.

The data to be reported must satisfy the general checks of the format or the belonging to a code list. The possibilities of the code also depend on the level of the data in the tree-structured menu.

The scheme contains format constraints for the data, but it does not necessarily specify the validity of a code that respects the format. The nomenclature as well as the rules defined in this manual must be respected.

2 Transmission

2.1 Attribution of the file name for regulated investment funds

The file name structure is the following:

S0000_L1_yyyymm_Rrrrrrrr_Dddddddd_yyyymmdd_nnn

where:

- S0000 represents the code of the statistical report
- L0 indicates that this version is layout 0
- yyyymm represents the year and the month the data refers to
- R identifies the type of the reporter
The reporter is the entity that submits the data.
The authorised values are displayed under point 4.
- rrrrrrrr allows the identification of the reporter
The identification numbers are allocated by the CSSF. The digits on the left are equal to 0.
- D identifies the type of *declarant*.
The *declarant* is the entity whose data are reported.
UCIs (*OPC*) and FIS must use the value O, SICAR the value K.
- dddddddd identifies the *declarant* i.e. the investment fund.
The identification numbers are those allocated by the CSSF. The digits on the left are equal to 0.
The identification number allocated by the CSSF is used: 5 digits for the number of the investment fund and 4 digits for the number of the compartment.
Example: compartment number 3 of investment fund number 122 is identified as follows 001220003.
- yyyymmdd is the creation date of the file
- nnn is the sequential number of the file
The sequential number of the file allows to separately identify files that are created on the same day for the same report. It should be noted that a new sequence must be started each day and that the sequential number starts at 001; thus 000 must not be used.

2.2 Attribution of the file name for Luxembourg's non-regulated investment funds

The file name structure is the following:

S0000_L1_yyyymm_Rrrrrrrrr_Ddddddddddddddd_yyyymmdd_nnn

where:

- S0000 represents the code of the statistical report
- L0 indicates that this version is layout 0
- yyyymm represents the year and the month the data refers to
- R identifies the type of the reporter
The reporter is the entity that submits the data.
The authorised values are displayed under point 4.
- rrrrrrrrr allows the identification of the reporter
The identification numbers are allocated by the CSSF. The digits on the left are equal to 0.
- D identifies the type of *declarant*.
The *declarant* is the entity whose data are reported.
Nonregulated alternatif investment funds must use the value NAF.
- ddddddddddddddd identifies the *declarant* i.e. the investment fund.
The identification numbers are related to the identifier allocated by the Luxembourg trade and company register (RCS *registre du commerce et des sociétés*).
The identification number allocated is defined as : 2 digits for the letter (66 for B and 75 for K), 7 digits for the number of the investment fund and 5 digits for the number of the compartment. In order to fit the pattern, the digits on the left are equal to 0.
Example: compartment number 1 of investment fund with RCS number B123456 is identified as follows 66012345600001.
- yyyymmdd is the creation date of the file
- nnn is the sequential number of the file
The sequential number of the file allows to separately identify files that are created on the same day for the same report. It should be noted that a new sequence must be started each day and that the sequential number starts at 001; thus 000 must not be used.

2.3 File names currently in use for regulated investment funds

The following table provides an overview of all the statistical reports currently in force.

Report	Name
S 1.3 L3	S0103_L3_yyyymm_Rrrrrrrrr_Dddddddddd_yyyymmdd_nnn
S 1.6 L1	S0106_L1_yyyymm_Rrrrrrrrr_Dddddddddd_yyyymmdd_nnn
S 2.13 L1	S0213_L1_yyyymm_Rrrrrrrrr_Dddddddddd_yyyymmdd_nnn
TPTOBS L2	TPTOBS_L2_yyyymm_Rrrrrrrrr_Dddddddddd_yyyymmdd_nnn

Example 1:

S0103_L3_201412_B000000789_O001220003_20150109_001.xml corresponds to the first file created on 9 January 2015, submitted by credit institution number 789, the data refers to the compartment number 3 of investment fund number 122 for the period December 2014.

Example 2:

S0213_L1_201412_O0000001220000_O001220003_20150120_001.xml corresponds to the first file created on 20 January 2015, submitted by investment fund number 122, the data refers to the compartment number 3 of investment fund number 122 for the period December 2014.

2.4 File names currently in use for Luxembourg's non-regulated investment funds

The following table provides an overview of all the statistical reports currently in force.

Report	Name
S 1.6 L1	S0106_L1_yyyymm_Rrrrrrrrr_NAFddddddddddddddd_yyyymmdd_nnn
S 2.13 L1	S0213_L1_yyyymm_Rrrrrrrrr_NAFddddddddddddddd_yyyymmdd_nnn
TPTOBS L2	TPTOBS_L2_yyyymm_Rrrrrrrrr_NAFddddddddddddddd_yyyymmdd_nnn

Example 1:

S0213_L1_201809_B000000789_NAF66012345600001_20181020_001.xml corresponds to the first file created on 20 October 2018, submitted by credit institution number 789, the data refers to compartment number 1 of the investment fund having B123456 as RCS number, for the period September 2018.

Example 2:

S0213_L1_201809_NAF75000123400000_NAF75000123400001_20181020_001.xml corresponds to the first file created on 20 October 2018, submitted by investment fund having K1234 as RCS number, the data refers to compartment number 1 of the investment fund having K1234 as RCS number, for the period September 2018.

2.5 Means of transmission

The BCL accepts the use of the current electronic transmission channels offered by Sofie (SIX Payment Services (Europe) S.A., CETREL Securities) and e-file (Bourse de Luxembourg, Fundsquare).

However, the BCL is willing to accept any new secure transmission channel that is accepted by both, the BCL and the reporting agents.

3 XML schemes for statistical reports

The XML schemes and a technical documentation are available for downloading on the BCL's website. It is important to know that the design of the XML reporting is based on a tree-structured menu.

The data to be reported must satisfy the general checks of the format or the pertaining to a code list.

The possibilities for the codes also depend on the level of the data in the tree-structured menu.

The scheme contains format constraints for the data, but it does not necessarily specify the validity of a code that respects the format. The nomenclature as well as the rules defined in this manual must be respected.

4 Identification of the reporter and the declarant

The identification of the reporter (*reporterID*) and the identification of the *declarant* (*declarantID*) include each the type of the identification number (*type*) and the identification number (*code*).

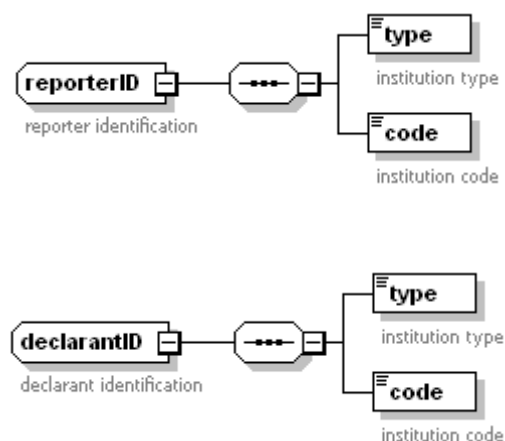

The association of number types and authorised values are:

Type of identification number	Identification number	<i>in the filename</i>
01	Number allocated by the CSSF to other entities	<i>1</i>
05	Number allocated by the BCL to resident entities non-registered by the CSSF	<i>5</i>
06	Number allocated by the BCL to non-resident entities	<i>6</i>
23	Number allocated by the CSSF to banks	<i>B</i>
26	Number allocated by the CSSF to the UCIs (5 digits) and to the compartments (4 digits).	<i>O</i>
27	Number allocated by the CSSF to the SICAR (<i>sociétés d'investissement à capital risque</i>)	<i>K</i>
30	Number allocated by the CSSF to management companies	<i>S</i>
32	Number allocated by the CSSF to professionals of the financial sector	<i>P</i>
36	Number allocated by the CSSF to professionals of the financial sector – support	<i>I</i>
40	Number allocated by the CSSF to alternative investment fund managers	<i>A</i>
42	Number allocated by the BCL to non-regulated Luxembourg's alternative investment funds	<i>NAF</i>